

preliminary chamber design for triplet polarimeter from ASU machine shop



M. Dugger, January 2014



View 1

Mounting plate shown in **rust color**

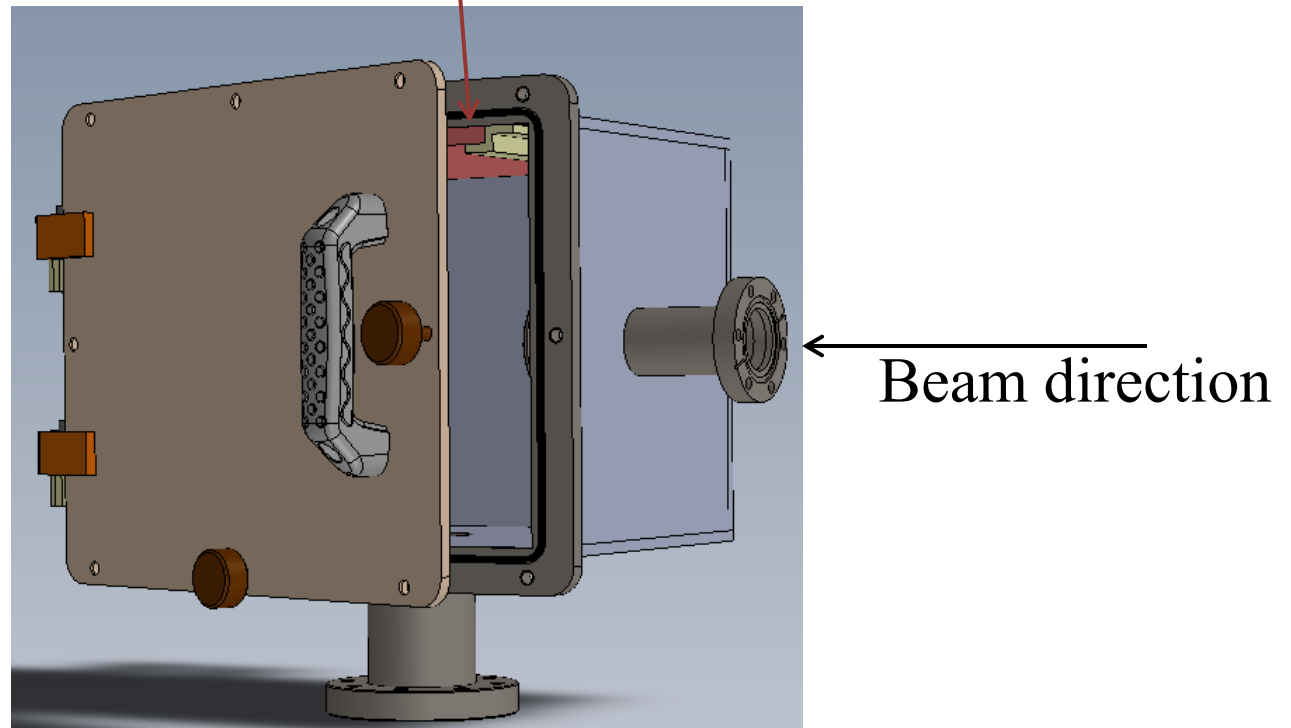

View 2

6 inch flange for electrical feed through

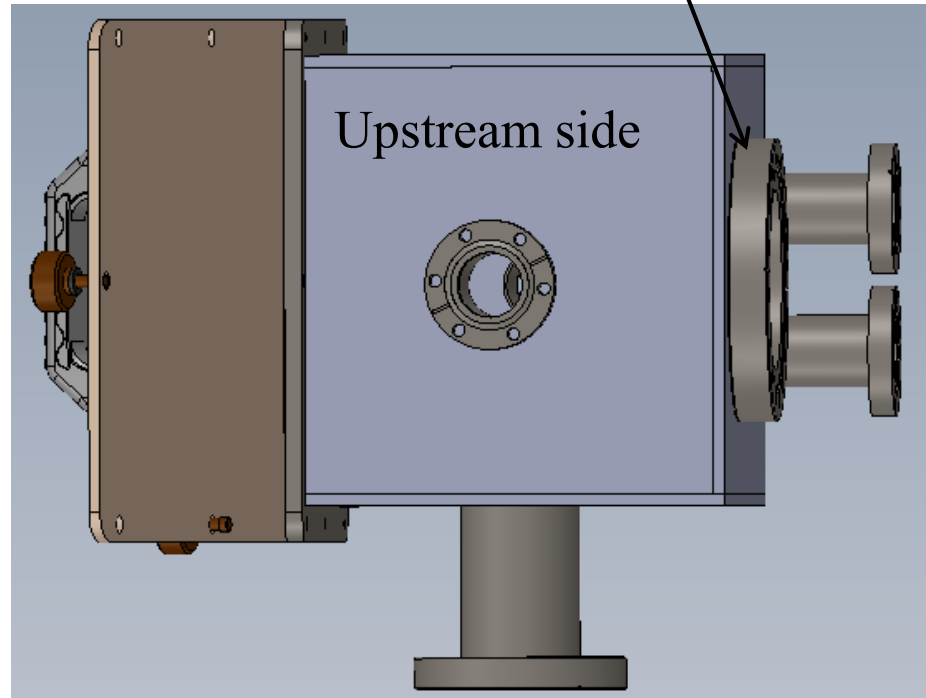

View 3

Position of 6 inch flange not finalized yet

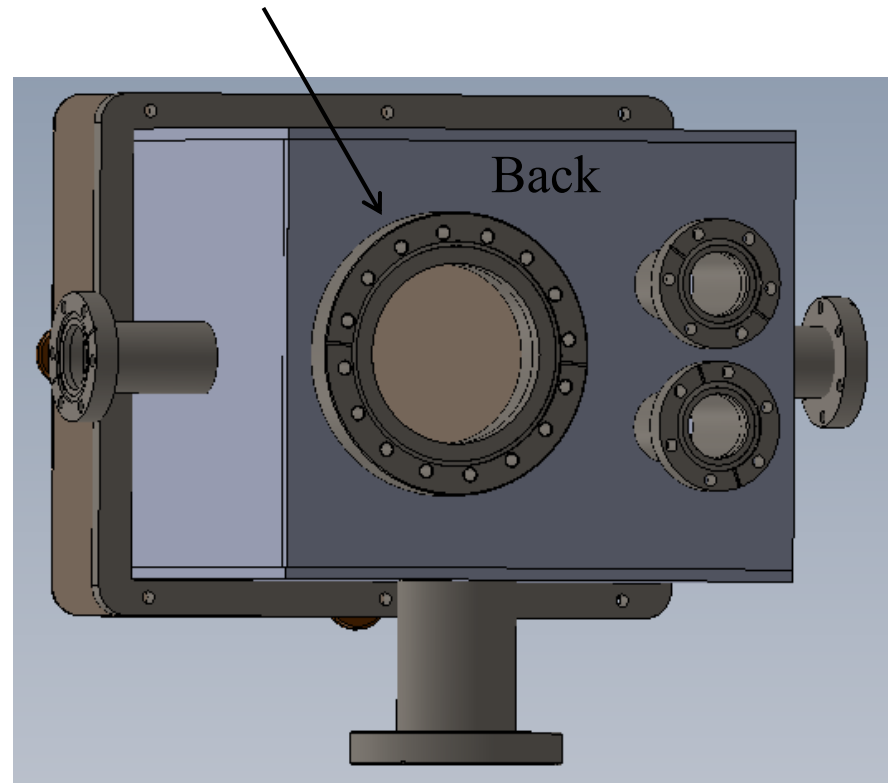

View 4

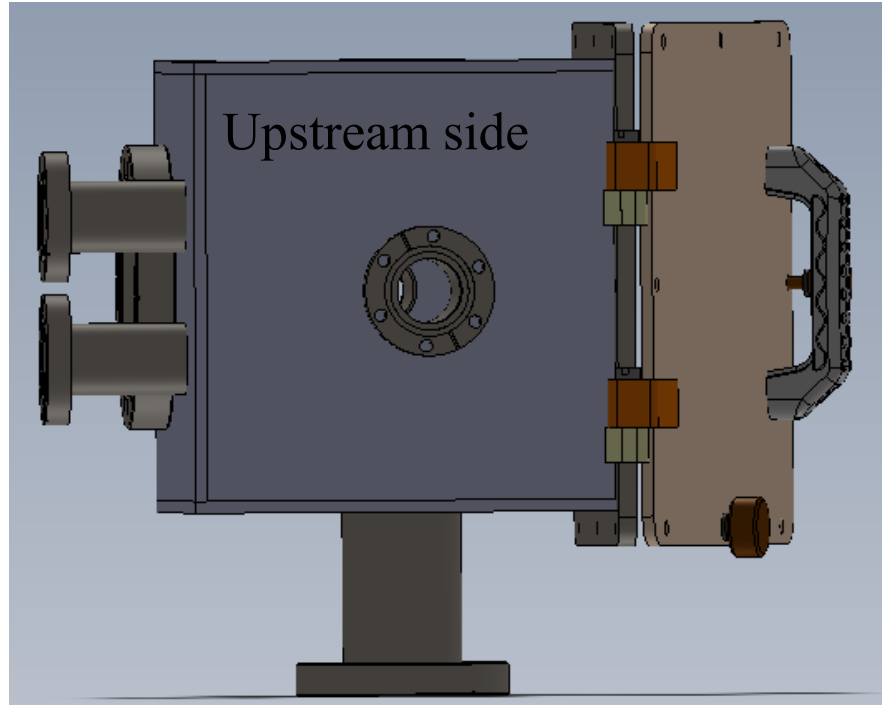

View 5

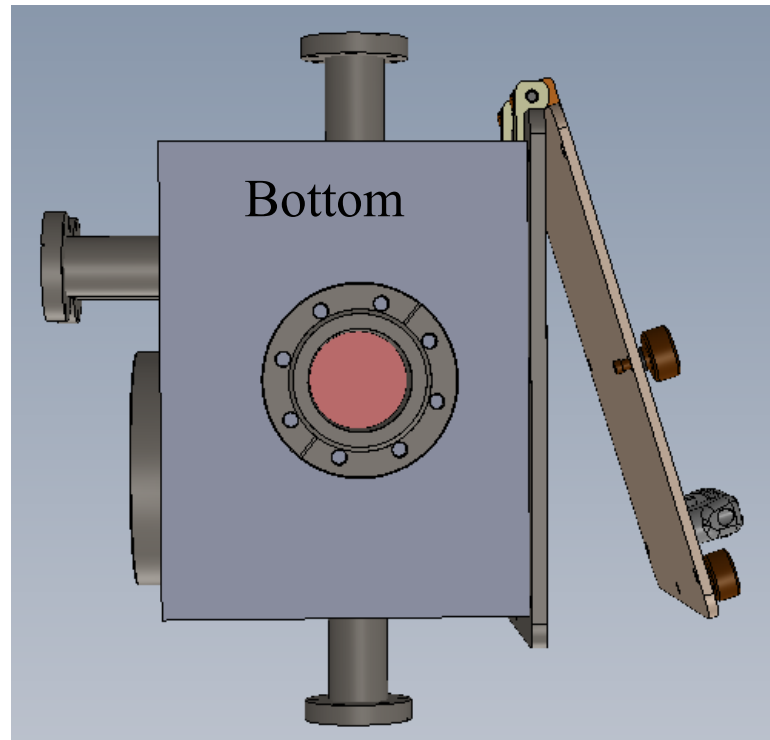

From here

- Have sent design files to Tim Witlatch and Ken Livingston for review
- The next design will include the converter stick and mounting brackets for the polarimeter
- Once design is final (and approved by Tim) the chamber is built