

PHY 132 – Summer 2000

LAB 2: Ohm's Law¹

Introduction:

In this lab, we look at the concepts of electrical resistance and resistivity. These concepts are covered in PHY131 much later in the semester, yet they are not difficult and can be learned here. In addition students may wish to read the appropriate sections of their PHY131 textbook. We use this lab partly as an exercise in data fitting.

Special equipment notes:

1. Note the tips on wiring and meters attached at the end of this lab. Save that sheet for future labs.
2. The DC supply includes a current-limit safety feature. You cannot exceed a set value, and a front-panel light will come on. Avoid this. Also, since this is a “constant voltage” supply, you should find voltage readings to be quite steady, while current readings may vary with contact resistance, etc.

Theory:

Ohm's law states that the voltage drop V (volts) across a resistor R (ohms) is proportional to the current flow I (amps), namely

$$V = IR \qquad \text{eq. 1}$$

A sample that follows this equation is said to be “ohmic”. It is also useful to define resistivity ρ as

$$R = \rho L/A, \qquad \text{eq. 2}$$

where L and A are the length and cross-sectional area of an object through which current is flowing. Resistivity is a material property (like density), which is independent of size or shape. It can be seen that the units of resistivity are ohms * length, conventionally ohm-cm.

¹ Adapted by R. J. Jacob from P. Bennett, PHY-132 Lab Manual© (ASU)

Procedure:

Part 1: (I, V) for carbon resistor.

1. Find the nominal value of R, based on the color code.
2. Measure R using the ohm range of the Digital Multimeter (DMM). R must be out of the circuit!
3. Connect the circuit shown in Fig. 1 below. Technical note: Meters can influence sensitive circuit measurements. Namely, the current through the A-meter includes both the sample and the V-meter currents. The V-meter, however, draws negligible current for the samples we use.
4. Tabulate (I,V) in the range 0 - 15V. Take data both on the way up and on the way down (about 10 pts total, matching V on up/down). This repeated measurement serves to establish error bars for your data.

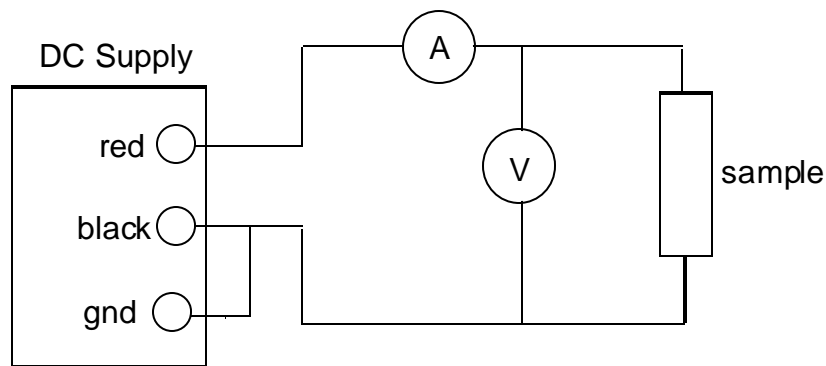

Fig.1. Circuit for measuring resistance

Part II: (I,V) for light bulb.

1. Measure R using the ohm range of the DMM.
2. Tabulate (I,V) in the range 0 – 6.5V (rated voltage for the bulb). Take data both on the way up and on the way down (about 20 pts total). This repeated measurement serves to establish error bars for your data.

Part III: Resistivity of graphite.

1. We want to find $\rho(I,V,L,A)$. “A” is constant, determined from the diameter of the rod. You should take (I,V) data at about 5 different values of L (separation of alligator clips), both for increasing and decreasing L.
2. “L” should be measured with the vernier calipers, from the outside of the clips, since you can get an accurate reading this way. It would be prudent, in addition, to measure the width of the clips (along the length of the rod).

Analysis:

Part 1.

1. Find R for the carbon resistor from a plot of (I,V), and compare with the DMM reading and color code value.
2. Is this sample ohmic?

Part 2.

1. Find R for the light bulb from a plot of (I,V). Why is it larger than the DMM reading?
2. Is this sample ohmic?

Part 3.

1. Find the resistivity of graphite from a plot of (R, L), where R is calculated from (I,V).
2. Is there a non-zero intercept to your fit-line, and what is its meaning?

Wiring tips: (refer to this page in all subsequent experiments)

1. Arrange components similar to shown in the schematic, both position and orientation.
2. Connect ground wires first, using black wires.
3. Connect circuit “hot” (non-ground) wires next (not black), following carefully around one circuit loop at a time, leaving (volt-)meters and scopes out for now. Current meters must be included, however, in circuit loops.
4. Every component must have at least two connections for current flow in/out. Any connections after the first must go to the correct terminal.
5. Connect voltmeters last (this includes scopes). They do not affect current flow.

Multi-Meters:

Digital multimeters (DMM) allow very accurate measurement of voltage, current or resistance, according to the range selector dial. It may also be necessary to change the input plugs accordingly. Keep the common (black) input, but move the other input (red) as needed. AC ranges are indicated with a wiggly line, DC with a straight line. Do not confuse current and voltage.

Current Measurement

While on current ranges, the meter presents a very low resistance (<1 ohm), hence dangerously high currents can flow even for small voltages in lab circuits. It is easy to “blow” a meter on current ranges. Partly for this safety reason, you must move the input wires to make current measurements.

Voltage Measurement

While on voltage ranges, the meter presents a very high resistance ($< 10^6$ ohms), hence essentially zero current flows, as desired for accurate readings. These measurements are fairly safe, as long as the input stays below the rated 400V.

Resistance Measurement

The meter sends a small test current through the sample and measures the voltage drop. Never use OHMS ranges on a live circuit. You must remove the component from the circuit first.