

## PHY132 – Summer 2010

### Ohm's Law

#### **Introduction:**

In this lab, we will examine the concepts of electrical resistance and resistivity. Text Reference Serway 27.2-4.

#### **Special equipment notes:**

1. Note the tips on wire and meters attached at the end of this lab. That sheet is useful for other labs as well.
2. The DC supply includes a current-limit safety feature. You cannot exceed a set value, and a front-panel light will come on. Avoid this. Also, since this is a “constant voltage” supply, you should find voltage readings to be quite steady, while current readings may vary with contact resistance, etc.

#### **Theory:**

The resistance (R) between two locations on a conducting object is defined as the slope of a graph of the applied voltage (V) between those two locations versus the current (I) which results from the applied voltage; i.e.

$$R \equiv \frac{dV}{dI}.$$

Such a graph, of the applied voltage versus the resulting current, is not generally a straight line. In general, more electronic current will result in more numerous and more energetic collisions with the lattice of ions through which the electrons are traveling; the increase in the number and energy of collisions results in more atomic motion in the lattice (a higher temperature for the conducting material) and increased resistance.

Ohm's Law does not apply to the general situation; instead, Ohm's Law states that the resistance is INDEPENDENT of the current through the object between the two selected locations; i.e. Ohm's Law states that the resistance of the object between the two selected locations is a constant. When Ohm's Law is true, the graph of applied voltage versus the resulting current IS a straight line, and the resistance is simply the slope of that line; i.e.

$$R = \frac{V}{I}.$$

A sample for which the resistance is constant over the range of applied voltages is said to be “ohmic”.

Whereas resistance is a property of a conducting object (specifically, of two selected locations on that conducting object), resistivity ( $\rho$ ) is a property of the conducting MATERIAL. The resistivity of a conducting material depends on the number of conduction electrons per unit volume in that material and on the effective frictional force on each moving electron per unit electron drift speed. If the resistivity of the material is known, then for a cylindrical geometry of cross-sectional area  $A$  and length  $L$ , the resistance  $R$  between the ends of the cylinder can be calculated from

$$R = \rho \frac{L}{A},$$

so the units of resistivity are Ohms times meters.

### **Procedure:**

#### **Part 1: Graph of current versus voltage for a carbon resistor.**

1. Find the nominal value of  $R$ , based on the color code.
2. Measure  $R$  using the ohms range of the Digital Multimeter (DMM).  $R$  must be out of the circuit!
3. Connect the circuit shown in Fig. 1 below. Technical note: Meters can influence sensitive circuit measurements. Namely, the current through the ammeter includes both the sample and the voltmeter currents. The voltmeter, however, draws negligible current for the samples we use.
4. Tabulate current versus applied voltage in the range 0 - 15V. Take data both on the way up and on the way down (about 10 pts total, matching  $V$  on up/down). This repeated measurement serves to establish error bars for your data.

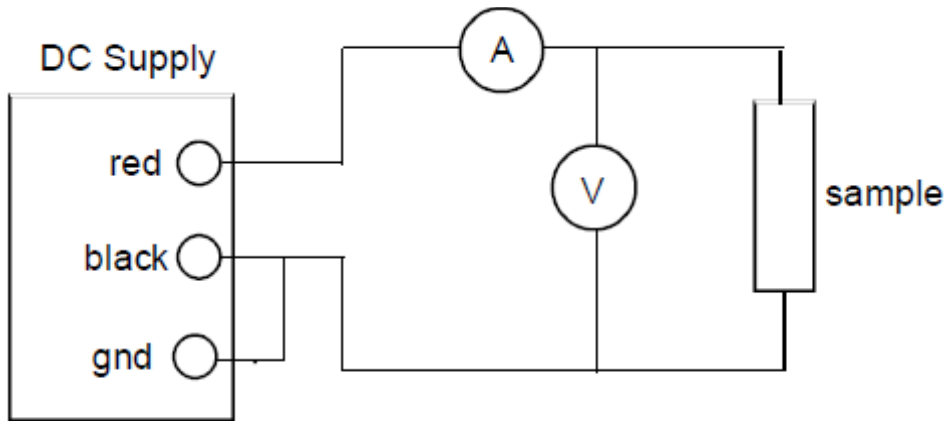

**Fig.1. Circuit for measuring resistance**

**Part II: Current versus applied voltage for a light bulb.**

1. Measure  $R$  of the light bulb using the ohms range of the DMM.
2. Tabulate current versus applied voltage in the range 0 – 6.5V (rated voltage for the bulb). Take data both on the way up and on the way down (about 20 pts total). This repeated measurement serves to establish error bars for your data.

**Part III: Resistivity of a graphitic material.**

1. You are provided with a thin conducting rod. The rod is composed mostly of graphite; however, there is also a significant concentration of non-graphitic impurities. Your task is to measure the resistivity of this composite conducting material. The cross-sectional area of the rod is to be determined from the diameter of the rod. You should take current versus voltage data at about five different values of  $L$ , where  $L$  is the length of the rod through which current is flowing. You need one complete set of data (five voltages) for each of five lengths. During this part of the experiment, you should allow the current to flow only for short periods of time; else, the graphitic rod may get dangerously hot, which could also cause the resistivity of the composite material to vary during the experiment.
2. The length  $L$  should be measured with the vernier calipers, from the inside of the clips.

## **Analysis:**

### **Part 1.**

1. Because the current is the result of the voltage we apply, it is most appropriate (though not most convenient) to put current on the vertical axis of your graph. Find  $R$  for the carbon resistor from a plot of current versus applied voltage, and compare with the DMM reading and color code value.
2. Is this sample ohmic; i.e. does it obey Ohm's law?

### **Part 2.**

1. Plot current versus applied voltage for the light bulb. Is this sample ohmic; i.e. does it obey Ohm's law?
2. Use your plot of current versus voltage to estimate  $R$  of the lightbulb when the current through the filament is small and again when the current is large. Compare your two values with the DMM reading for the light bulb? Explain any differences.

### **Part 3.**

3. Determine the resistivity of the graphitic material of which the rod is composed from a plot of resistance versus length, where each resistance is determined from a graph of current versus voltage for that length.
4. If there a non-zero intercept to your line of best fit for  $R$  versus  $L$ , what is its meaning?

## **Wiring tips:**

1. Arrange position and orientation of components as in the schematic.
2. Connect ground wires first, using black wires.
3. Connect circuit "hot" (non-ground) wires next (not black), following carefully around one circuit loop at a time, leaving voltmeters and scopes out for now. Current meters must be included, however, in circuit loops.
4. Every component must have at least two connections for current flow in/out. Any connections after the first must go to the correct terminal.
5. Connect voltmeters (and scopes) last. They do not affect current flow.

## **Multi-Meters:**

Digital multimeters (DMM) allow accurate measurement of voltage, current or resistance, according to the range selector dial. It may also be necessary to change the input plugs accordingly. Keep the common (black) input, but move the other input (red) as needed. AC ranges are indicated with a wiggly line, DC with a straight line. Do not confuse current and voltage.

### **Current Measurement**

While on current ranges, the meter presents a very low resistance ( $< 1 \text{ ohm}$ ), hence dangerously high currents can flow even for small voltages in lab circuits. It is easy to “blow” a meter on current ranges. Partly for this safety reason, you must move the input wires to make current measurements.

### **Voltage Measurement**

While on voltage ranges, the meter presents a very high resistance ( $< 10^6$  ohms), hence essentially zero current flows, as desired for accurate readings. These measurements are fairly safe, as long as the input stays below the rated 400V.

### **Resistance Measurement**

The meter sends a small test current through the sample and measures the voltage drop. Never use OHMS ranges on a live circuit. You must remove the component from the circuit first.

Prelab Quiz PHY132 Lab

Your name \_\_\_\_\_ Section \_\_\_\_\_ Time \_\_\_\_\_

1. Assume resistivity for Cu =  $1.7 \times 10^{-6}$  ohm-cm. Find the resistance of a 10 meter length of Cu wire of 0.5 mm diameter.
  
  
  
  
  
  
  
  
  
  
2. Find the voltage across this wire, if it is carrying 5.0 Amps current.