

**MAE 560/460 Applied Computational Fluid Dynamics**

Fall 2021 Tuesday/Thursday 1:30-2:45 PM, Classroom: DISCVRY 150

Instructor: Huei-Ping Huang (hp.huang@asu.edu), ERC 359

Office hours: Monday 3-5 PM, Tuesday 3-5 PM, or by appointment

**Course website <http://www.public.asu.edu/~hhuang38/ACFD2021.html>**

## Topics to cover

- **Techniques for solving incompressible and compressible flow equations using commercial/industrial solvers (We will use **Ansys-Fluent** as the principal tool)**
- **Computer-aided analysis of fluid systems**
- **Applications to thermofluid system engineering**

**No required textbook. Instructor will provide tutorials and lecture notes as needed.**

**Attendance is mandatory.**

## Planned activities

We will run two threads concurrently through the semester:

*Lecture* thread fills the background knowledge on fluid mechanics and numerical methods.

*Project* thread focuses on the execution and analysis of specific projects using Ansys-Fluent.

Ansys provides student version of their software for free, with some restrictions (limit of number of nodes, etc.). The student version of Ansys-Fluent is good enough for all projects in this class.

Ansys-Fluent is available on the computers in GWC 481/483 computing lab. You will have access to the lab. (Detail forthcoming.)

## Plan for the semester

### *I. Lectures*

1. Survey of basic fluid mechanics and thermodynamics as preparation for the projects (4 weeks)
2. Survey of numerical methods for deepening the understanding of the functionality of Ansys-Fluent or similar industrial software (6 weeks)
3. Discussion on more advanced topics in CFD (e.g., turbulence modeling) (3 weeks)

### *II. Projects*

1. Tutorials for Ansys-Fluent (2 weeks)
2. Main projects (12 weeks)

*At least four of the following projects (3 weeks each) will be chosen for this semester. The list is tentative and the detail of the individual project is subject to further adjustments.*

Project 1: Fluid system with heat transfer

Project 2: External flow (calculation of drag and lift; Reynolds number dependence)

Project 3: Compressible flow system

Project 4: Low Reynolds number flow; Microfluidics

Project 5: Moving boundary and moving grid

Project 6: Flow with an interface (two-phase or multi-phase)

**Grade:** Projects & homework - regular tasks ~ 90%

Final exam (in-class test) 10%

Specific rules concerning collaboration on projects/homework will be released along with the release of each assignment.

The required work for the projects will be different for participants of MAE560 and MAE460. Details will be given in the individual assignments.

**Please make sure that you are familiar with ASU policies on academic integrity:** <https://provost.asu.edu/academicintegrity>

## Some examples of computational fluid dynamics using commercial CFD solvers

Many commercial/industrial CFD solvers are available on the market. This class will use almost exclusively Ansys-Fluent but might include a quick exercise of a quick survey on other CFD solvers (Comsol, AcuSolve, Abacus, Autodesk Flow Design, etc.)

## Example 1 External flow - using *Autodesk Flow Design*

*Assessment of rooftop wind power potential*

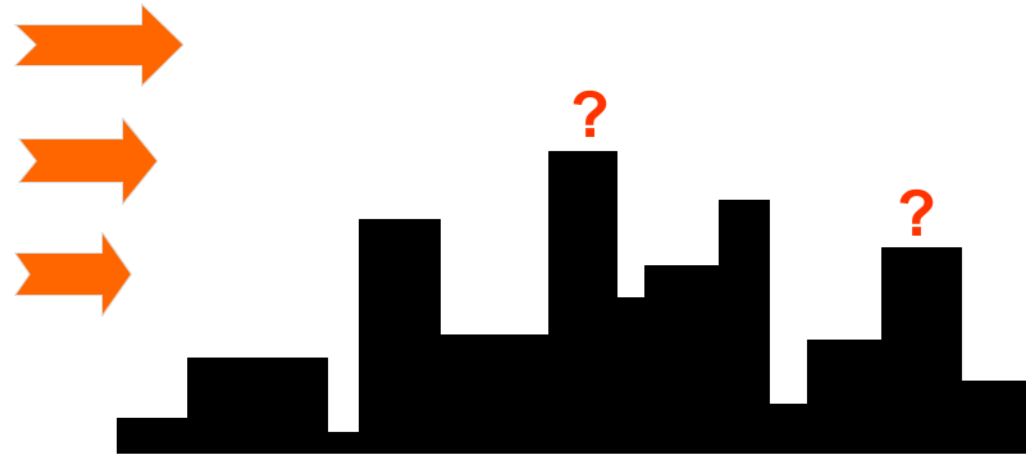

(Urban community, college campus, etc.)

## Simulation for Downtown Phoenix

[Research project, 2015, X. Ying (Huang group)]

- 3-D geometric data from Google Earth
- Keep 23 tallest buildings for flow simulation

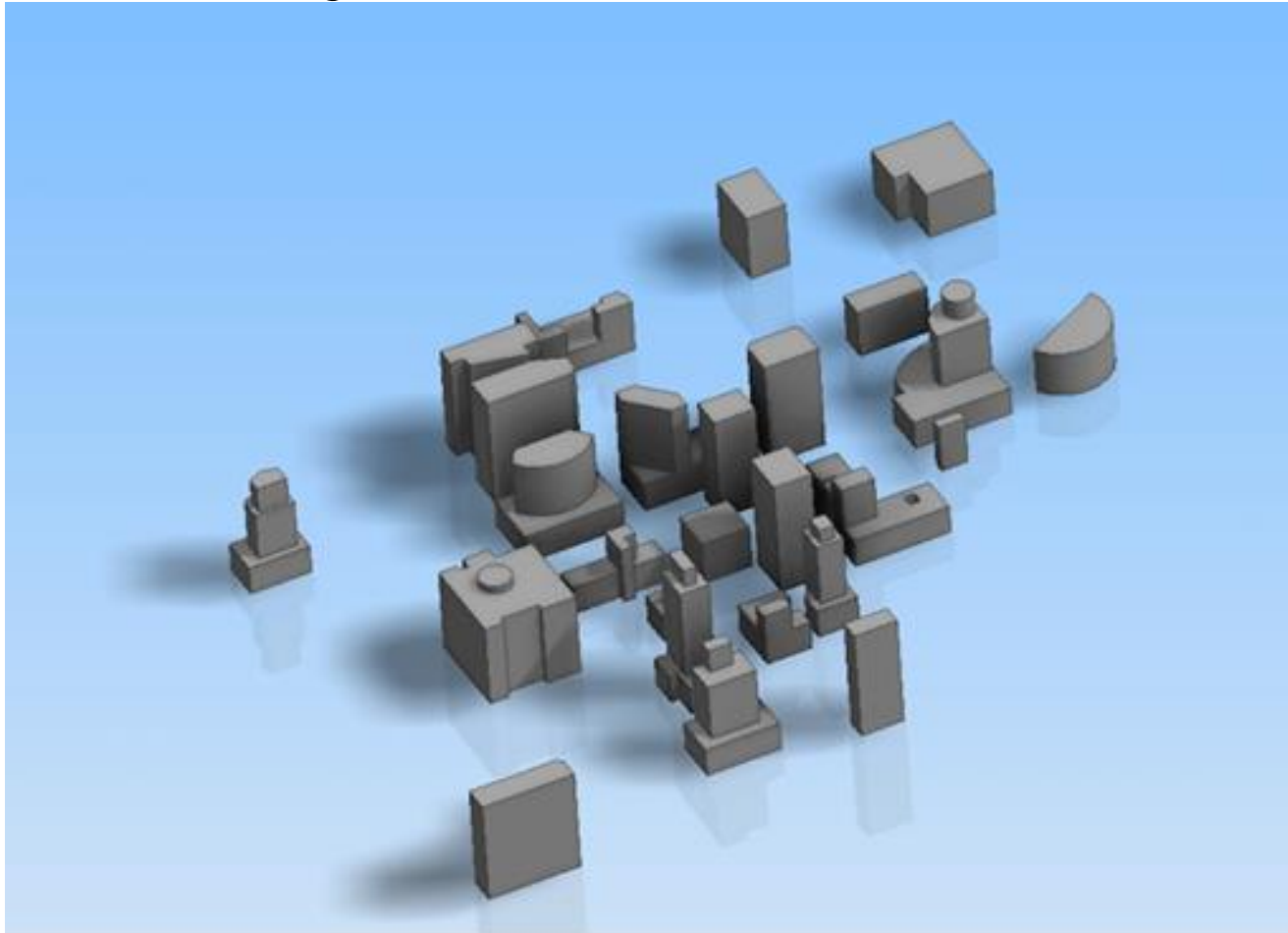



# Using Autodesk Flow Design - Model setup

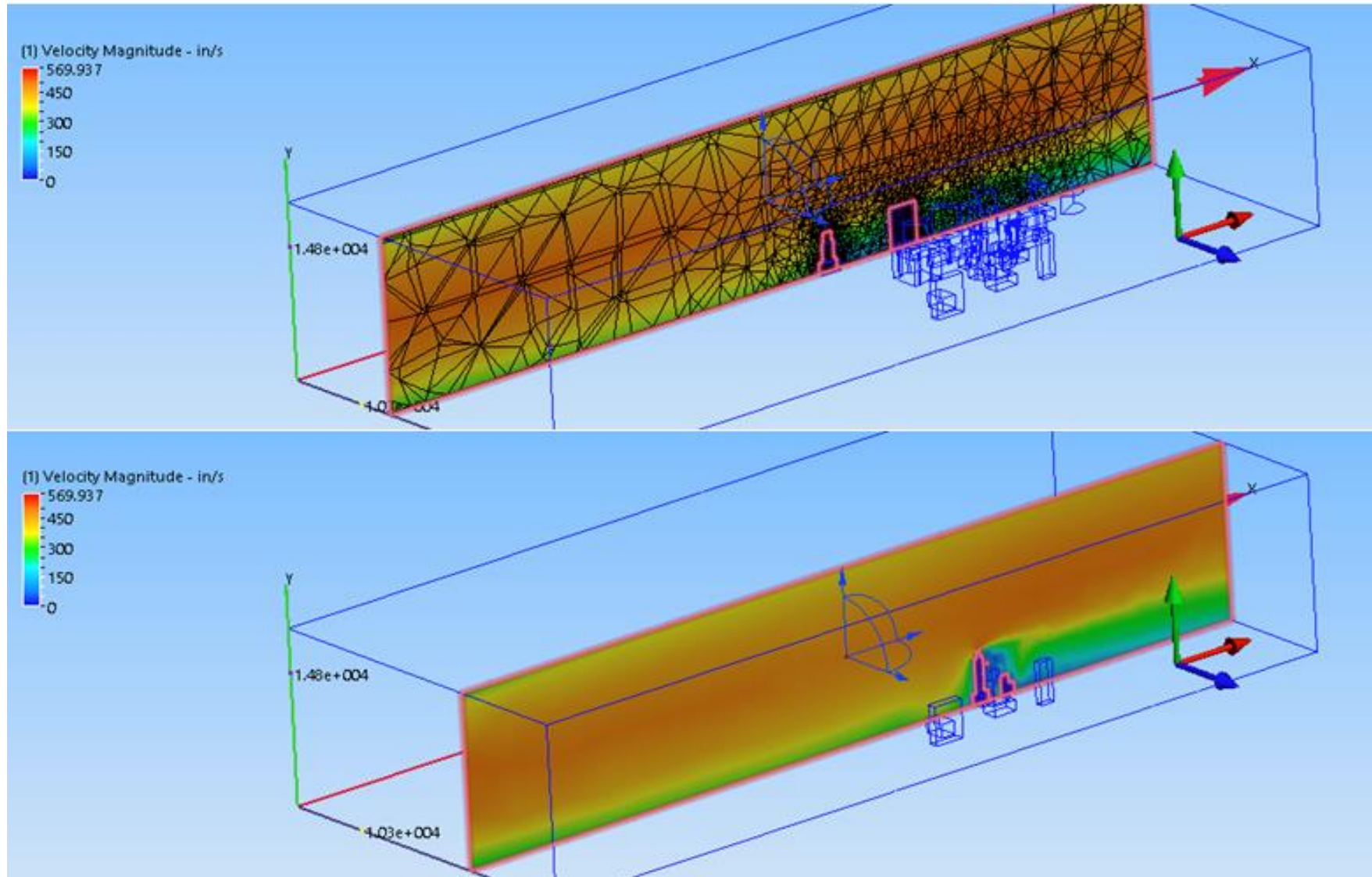

# Simulated wind speed (simplified version with fewer buildings)

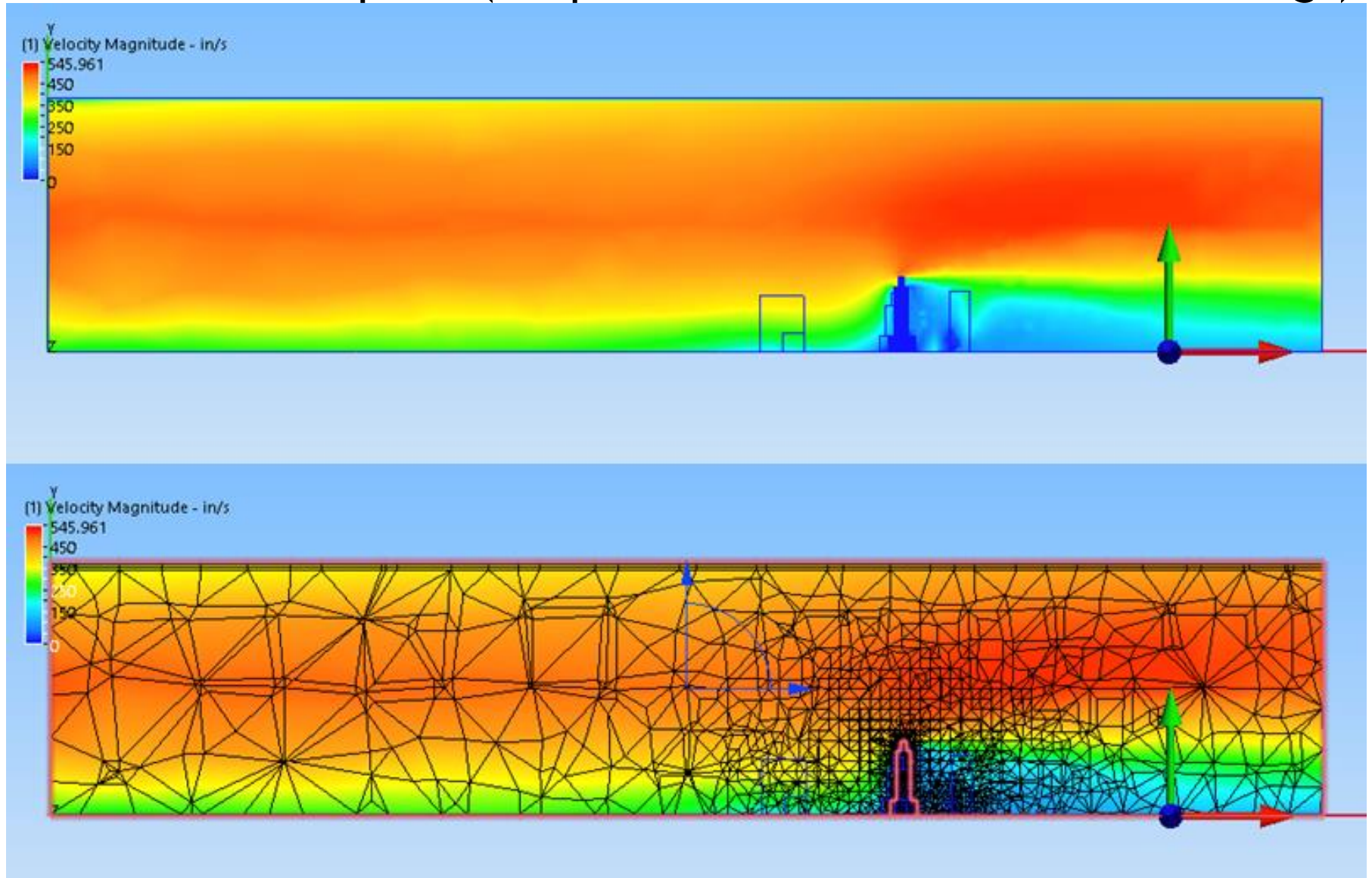

# Detail around the building - wind speed

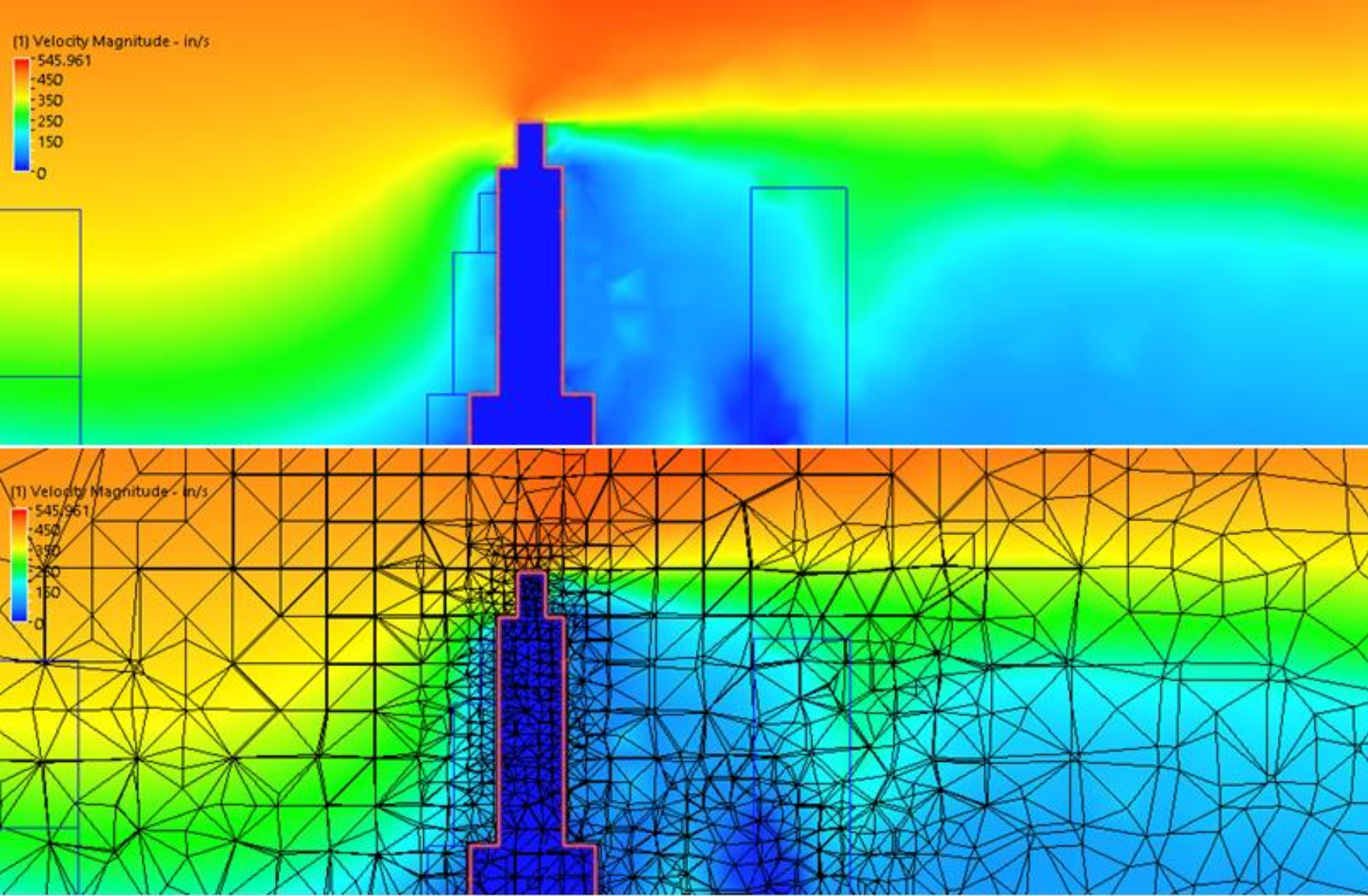

# Example 2 Internal flow - using *Ansys-Fluent*

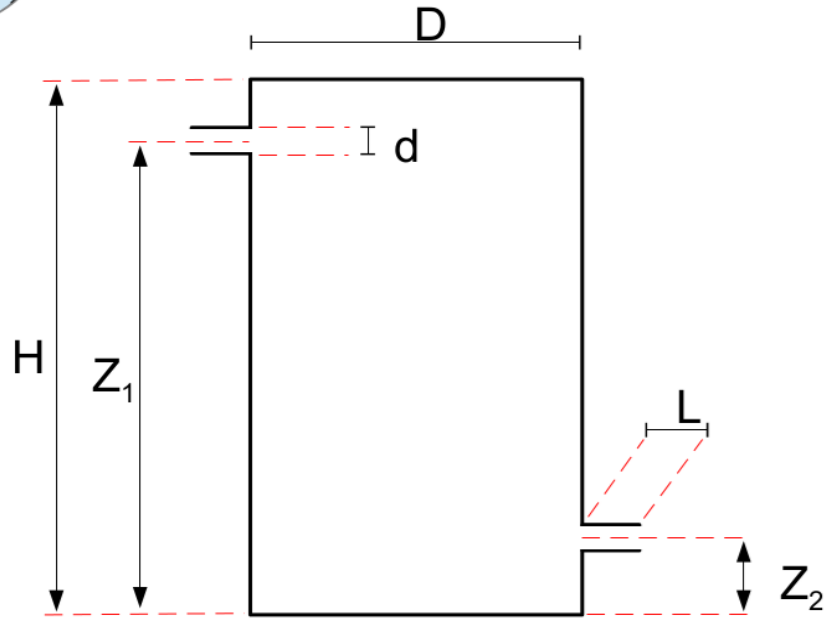
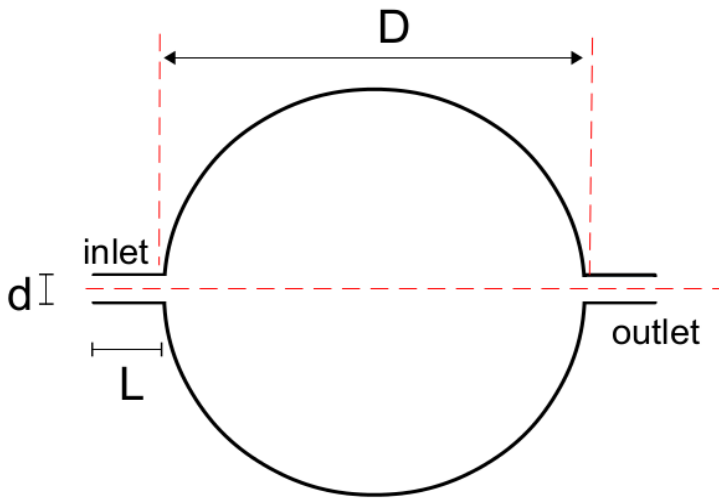
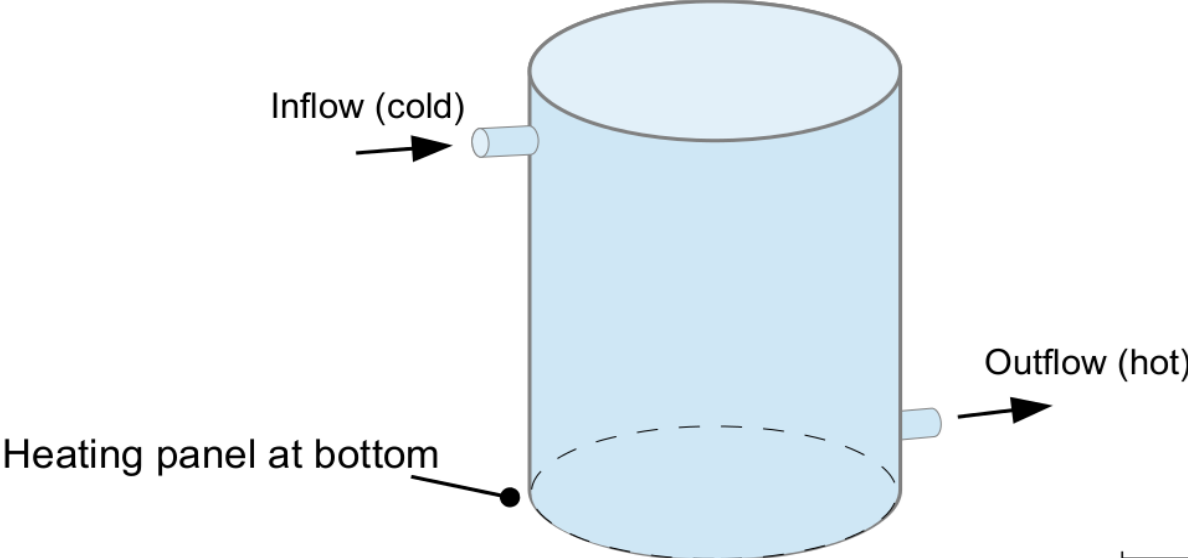

# Simulated temperature & velocity

## Temperature

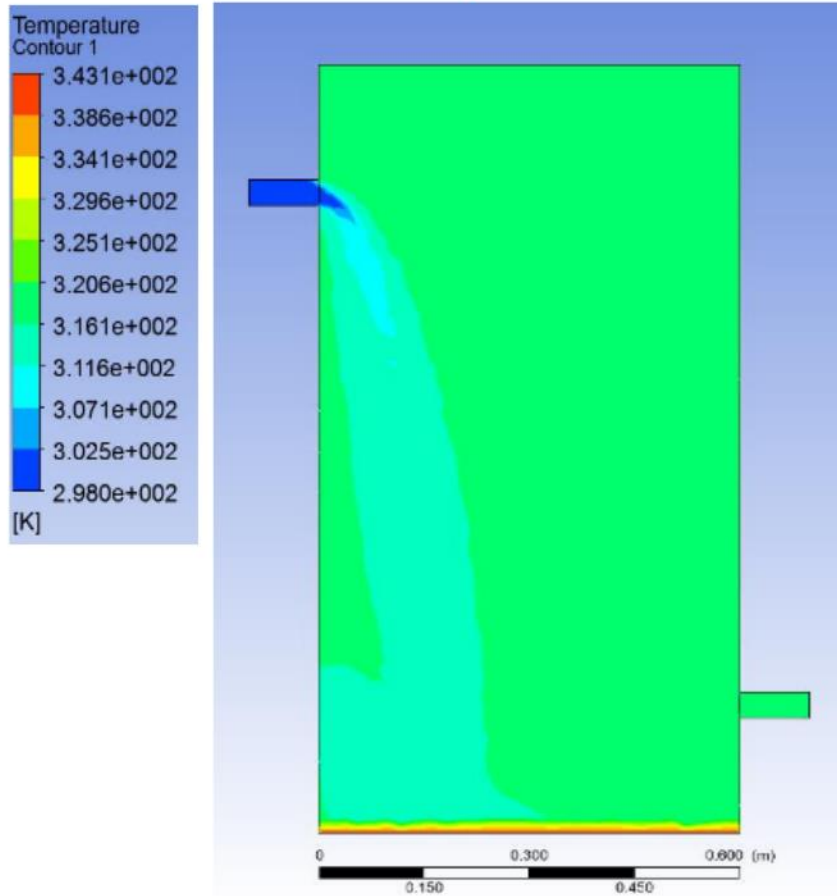

## Vertical velocity

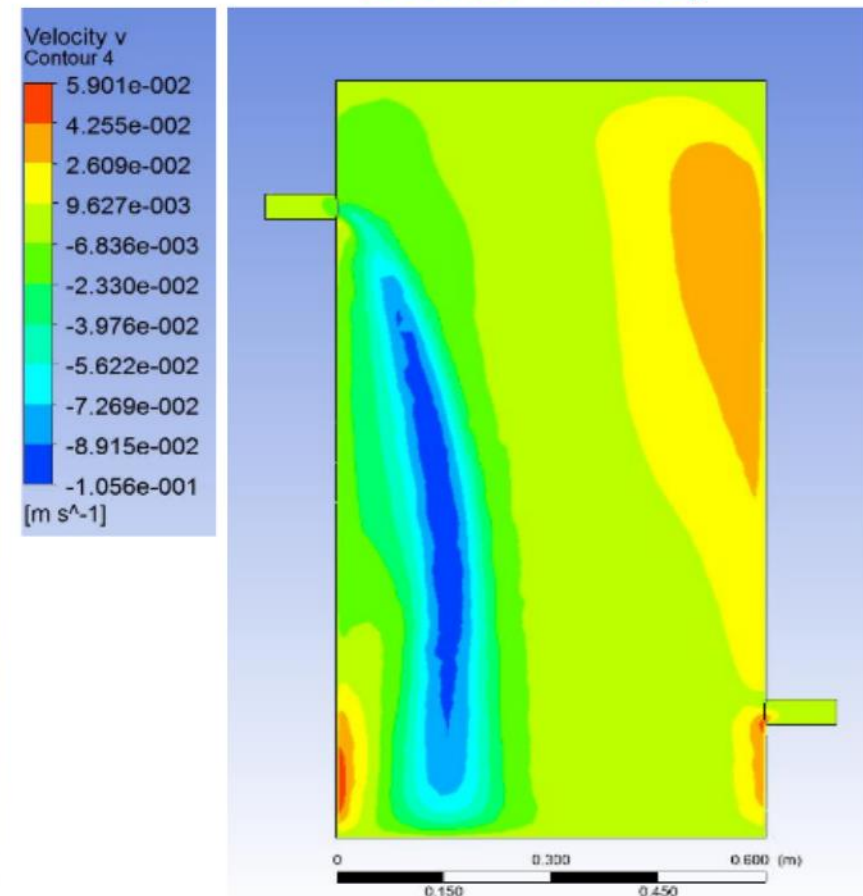

[Applied CFD course project, Fall 2015, A. Aguinaga (Instructor: HP Huang)]

# Stream lines

Plane of symmetry

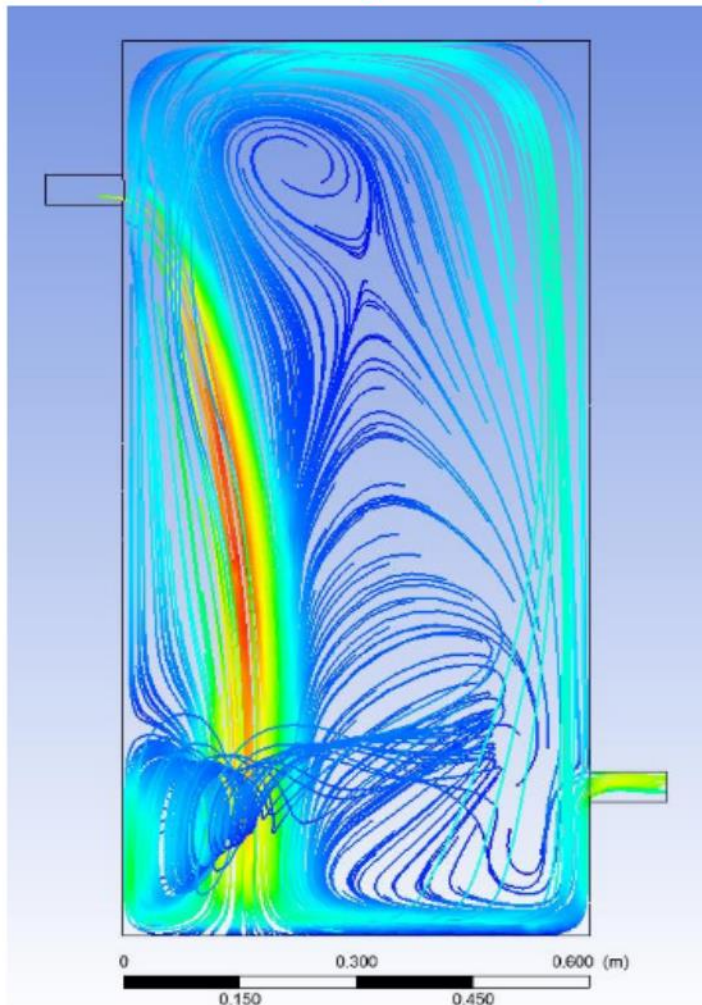

Side view

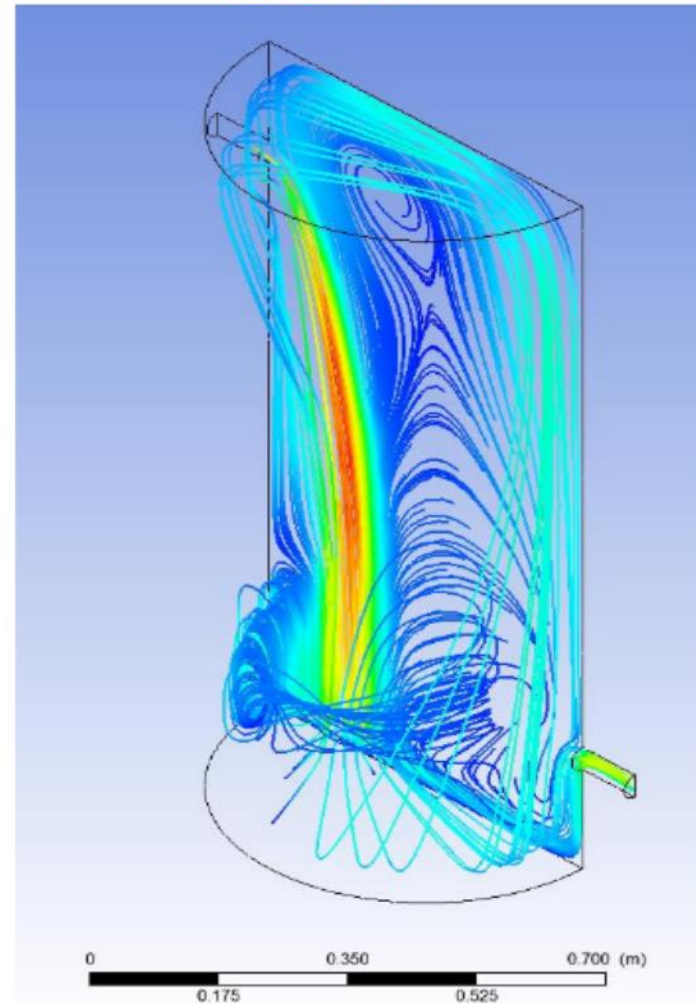

[Applied CFD course project, Fall 2015, A. Aguinaga (Instructor: HP Huang)]

Example 3 Two-phase flow in an open domain  
- using *Ansys-Fluent* (VOF method)

*Leak of methane from an underground reservoir into open air*

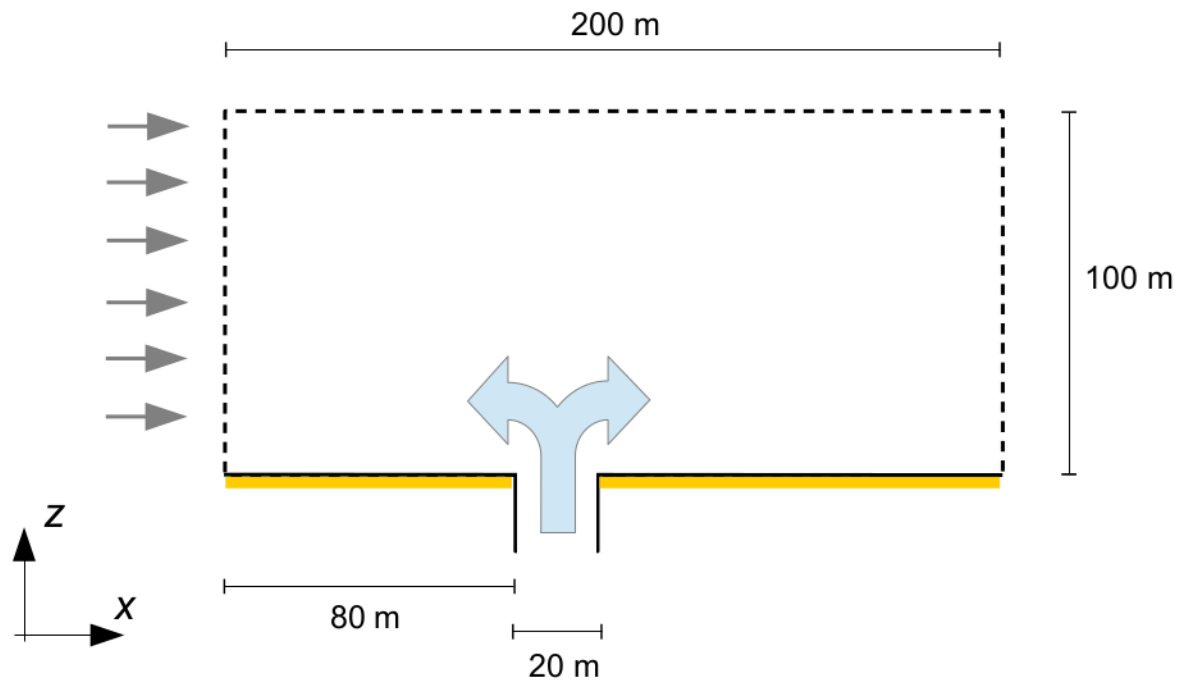

Low wind condition ( $U = 0.25 \text{ m/s}$ )

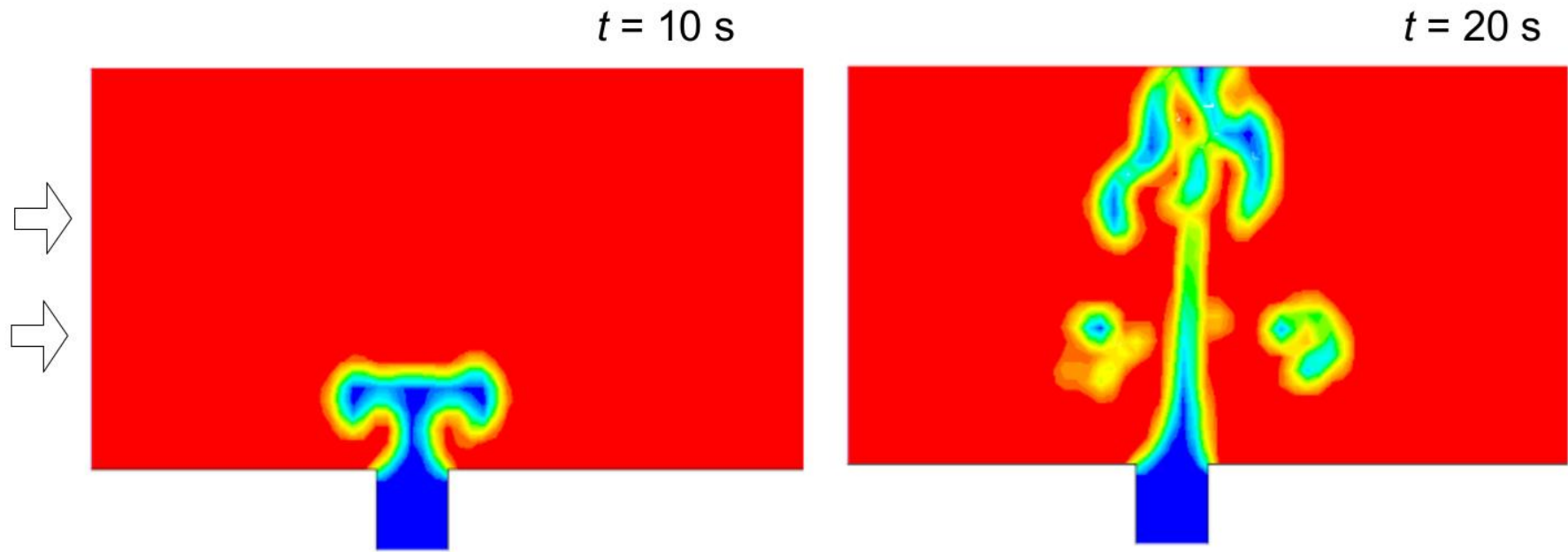

blue: methane, red = air, yellow/green = mixture

[Applied CFD course project, Fall 2015, Z. Damania (Instructor: HP Huang)]



High wind condition ( $U = 0.5 \text{ m/s}$ )

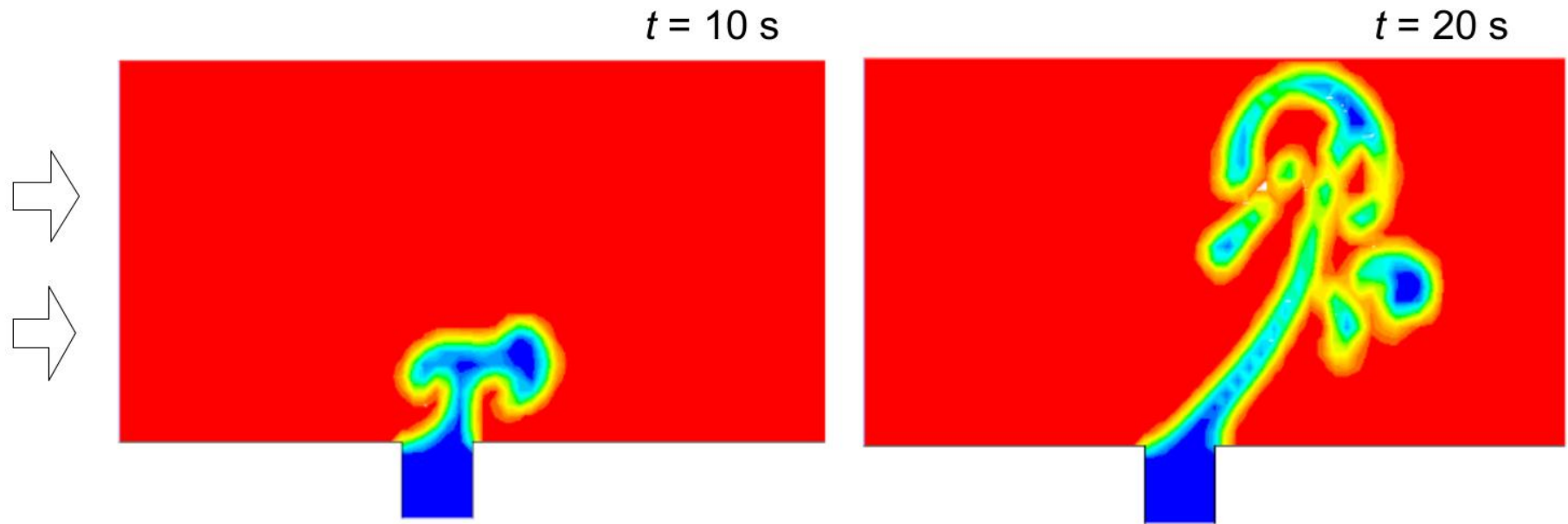

[Applied CFD course project, Fall 2015, Z. Damania (Instructor: HP Huang)]

## Example 4 Comparison of numerical simulation with lab experiment

### *Currents and waves in a rotating water tank* (which emulate large-scale environmental flows)

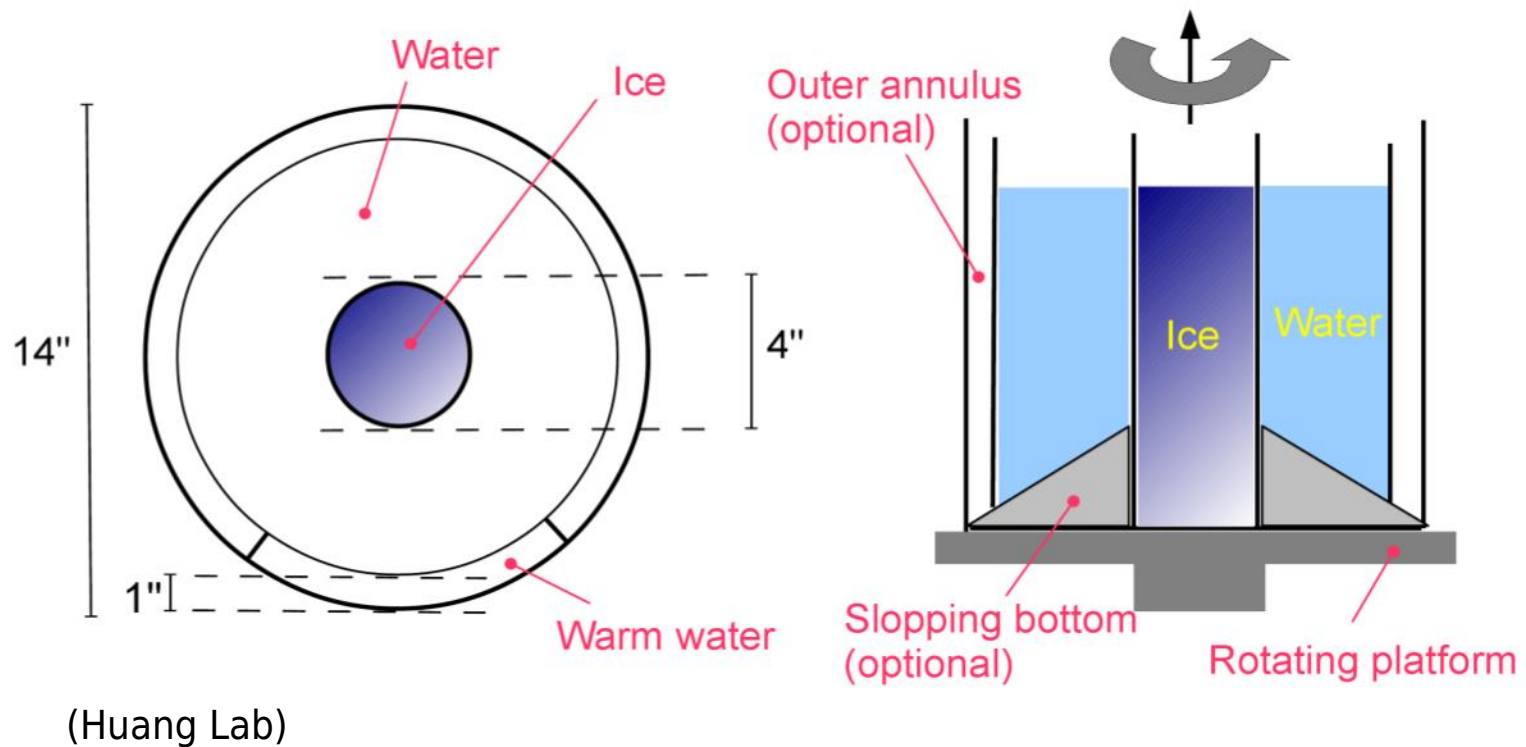

(Huang Lab)

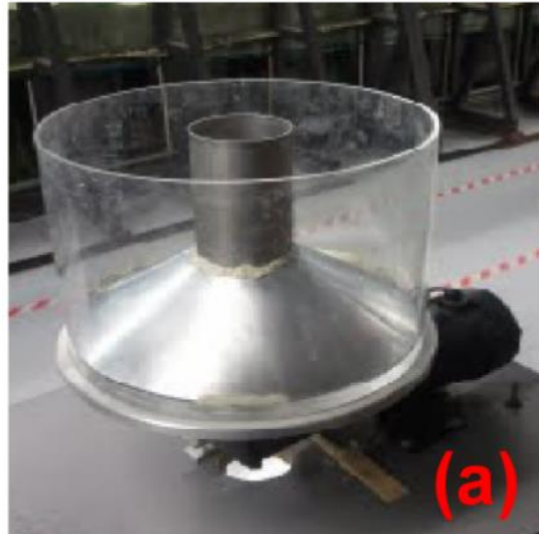

The apparatus

(Huang Lab)

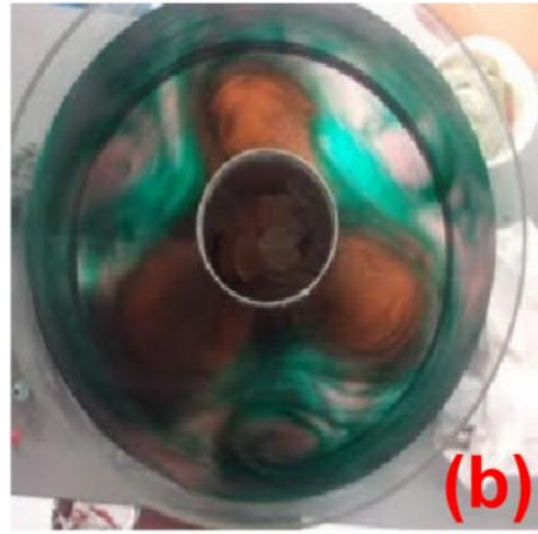

Experiment which shows  
a 3-wave structure  
(visualization by color dye)

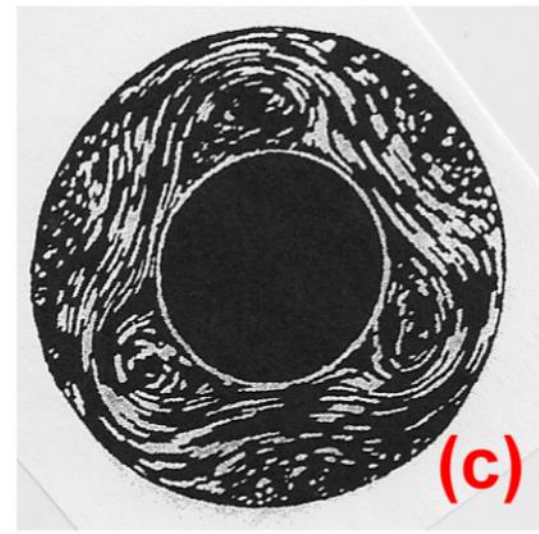

Classic result by  
Hide & Mason  
(streak photograph)

Simulate the system using *Ansys-Fluent*



Geometry & mesh

(N. Kulkarni , 2012, Applied Project)

# The simulation

Streamlines (top view)

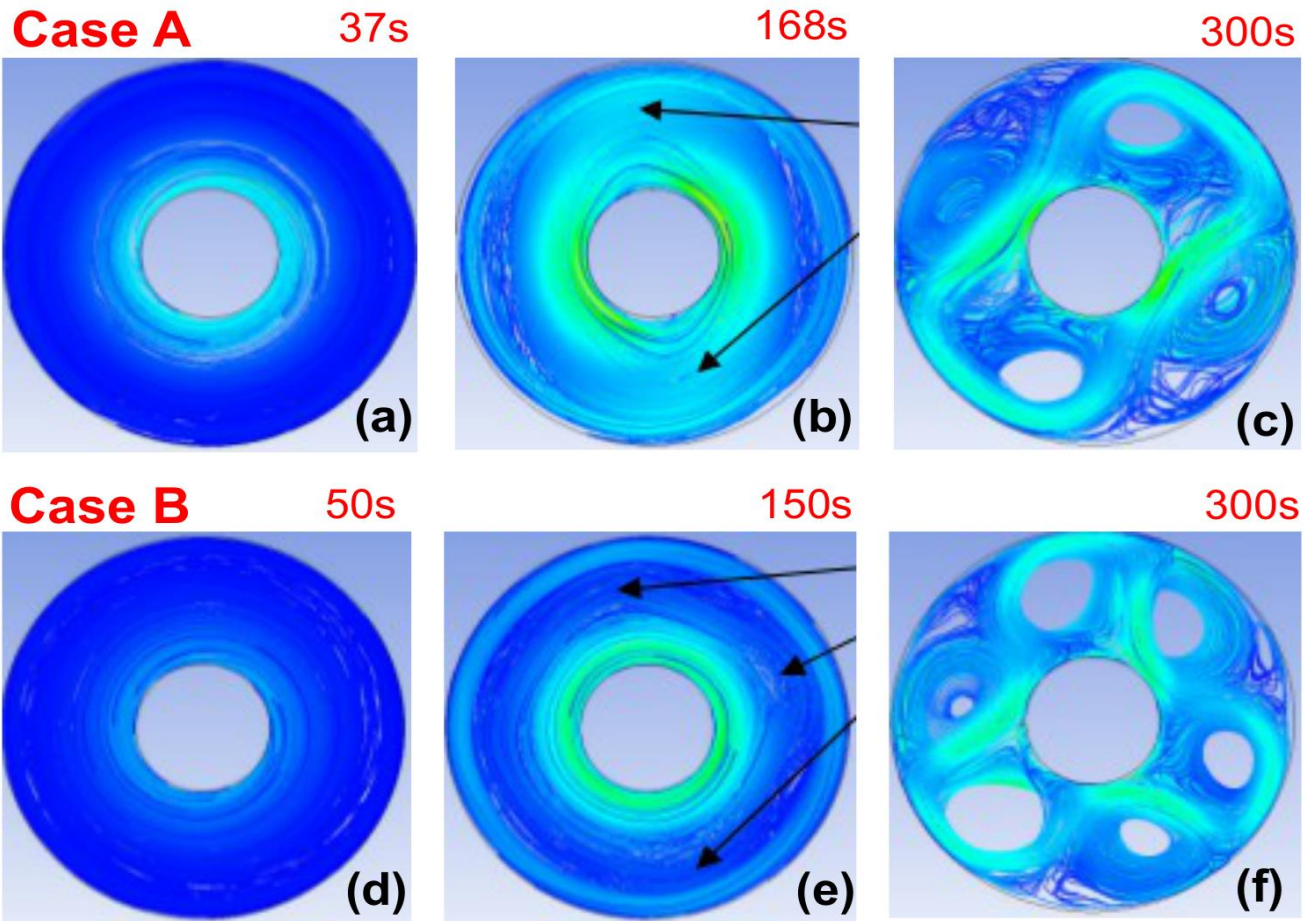

Case A: rotation rate = 0.942 rad/s, radial  $\Delta T = 30K$   
Case B: rotation rate = 0.942 rad/s, radial  $\Delta T = 15K$

(N. Kulkarni, 2012, Applied Project)

## Temperature: vertical cross section

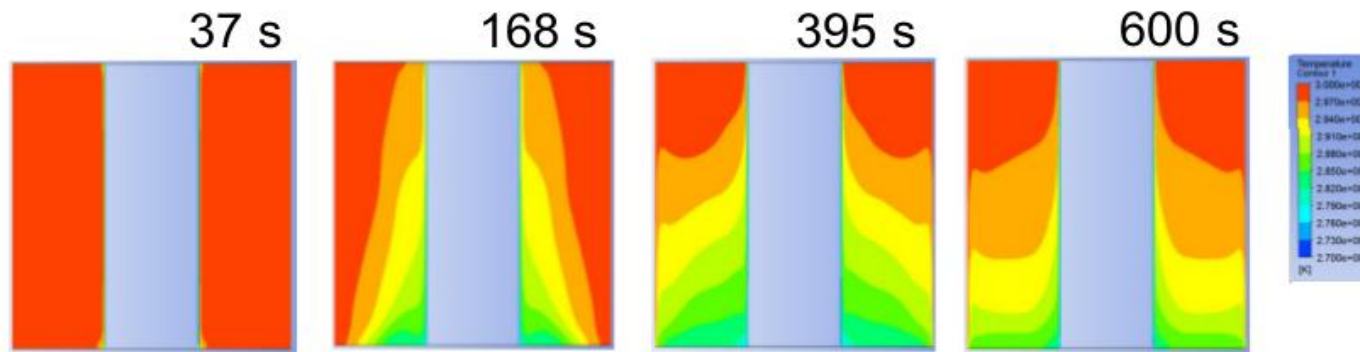

Case A: rotation rate = 0.942 rad/s, radial  $\Delta T = 30\text{K}$

(N. Kulkarni, 2012, Applied Project)

## Why numerical simulation ?

- Easy and cheap to modify the apparatus
  - Produces full 3-D fields (for velocity, temperature, etc.) which are otherwise hard to measure in the lab
  - Easy to adjust the external parameters (e.g., rotation rate of the water tank) for multiple experiments
- and more ...

### Caution: Computer model $\neq$ Reality

- Finite resolution
- Inaccuracies in numerical schemes
- Incomplete representation of physical processes etc.

## Facilities & software

Ansys-Fluent will be the main tool for all projects

- Use your own computer (desktop, laptop)
- GWC 481/483 Computing Lab  
Ansys + more are available on the computers
- Student version of Ansys can be downloaded from company website  
*Has limits on # of nodes and # of modules to open at once, but will be sufficient for the class projects*
- While Ansys-Fluent has its own post-processing tools, the output of simulation can also be analyzed with external software (e.g., Matlab)